

**Operating Dimensions**

Standard Tool Changer:  
20 Station Umbrella Tool Changer  
30+1 Station Side-Mount Tool Changer  
50+1 Station Side-Mount Tool Changer

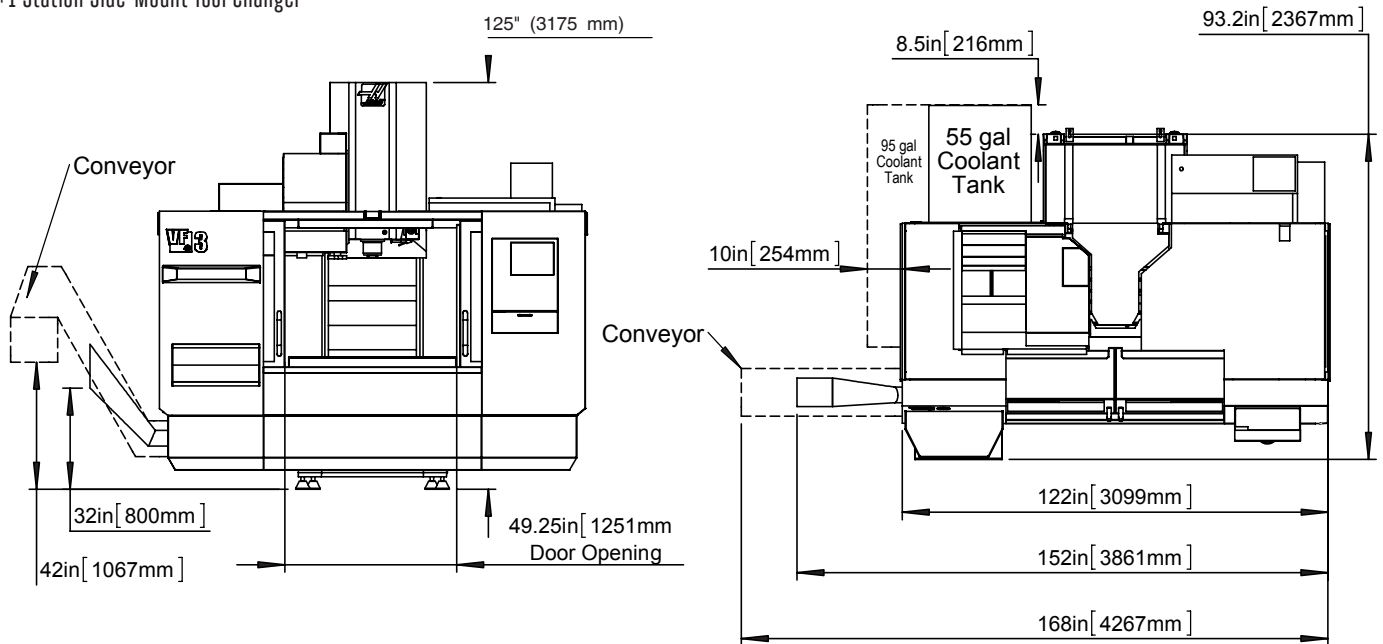

Option: Multi-Auger Chip Conveyor

Minimum distance required to remove conveyor from mill is 85in (2159mm) without folding the conveyor.

Minimum distance required to remove conveyor is 50in (1270mm) when the conveyor is folded at 90 degrees and folded down as if removed.

**Breakdown Height**

92.8in [2356mm] if the SMTC motor cover is removed and the motor is removed on non-SS machines.

94in [2388mm] if the Z-axis motor shroud is removed

90in [2286mm] Regen Box

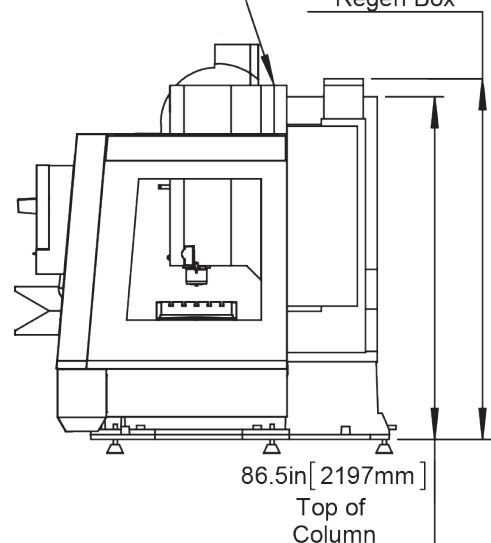
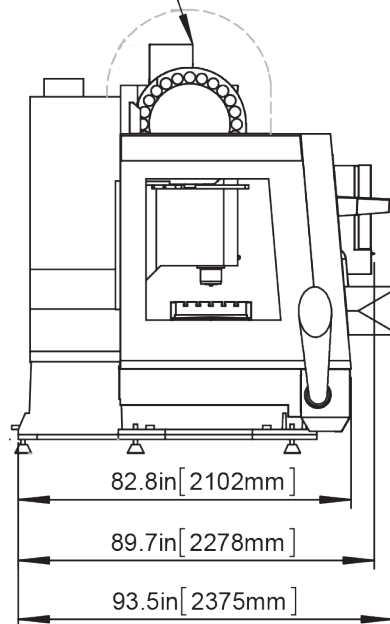

**X/Y Axis Clearances**

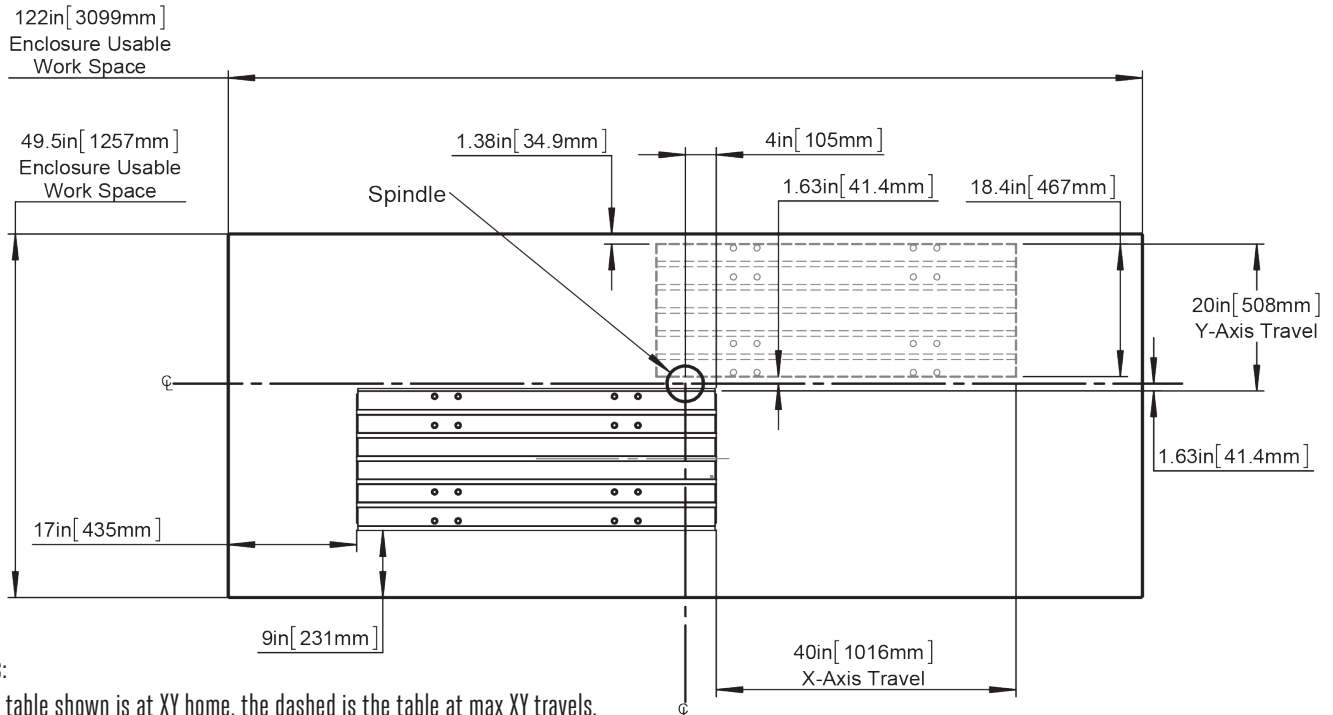

Notes:

1. The table shown is at XY home, the dashed is the table at max XY travels.
2. Measurements are from the edge of the table to the nearest obstruction.
3. Dimensions shown are at the top of the table. Dimensions are reduced as the height increased (5 degree slope inside the sheet metal).
4. Dimensions are symmetrical unless otherwise stated.

**Z Axis Clearances**

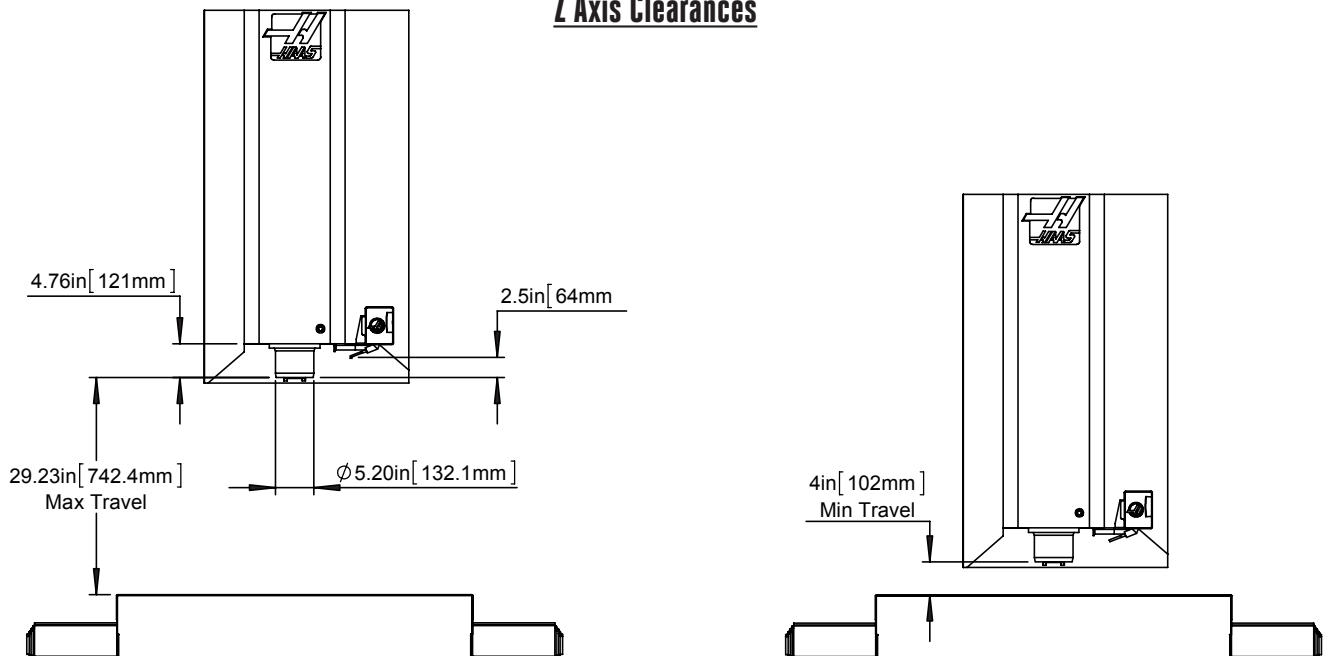

Notes:

1. The low-profile tables are 3 in(76mm) lower than the standard table.
2. P-COOL dimension varies based on P-COOL position.
3. Refer to the page on Tool Changer Dimensions for tool changer heights.

**Table Dimensions**

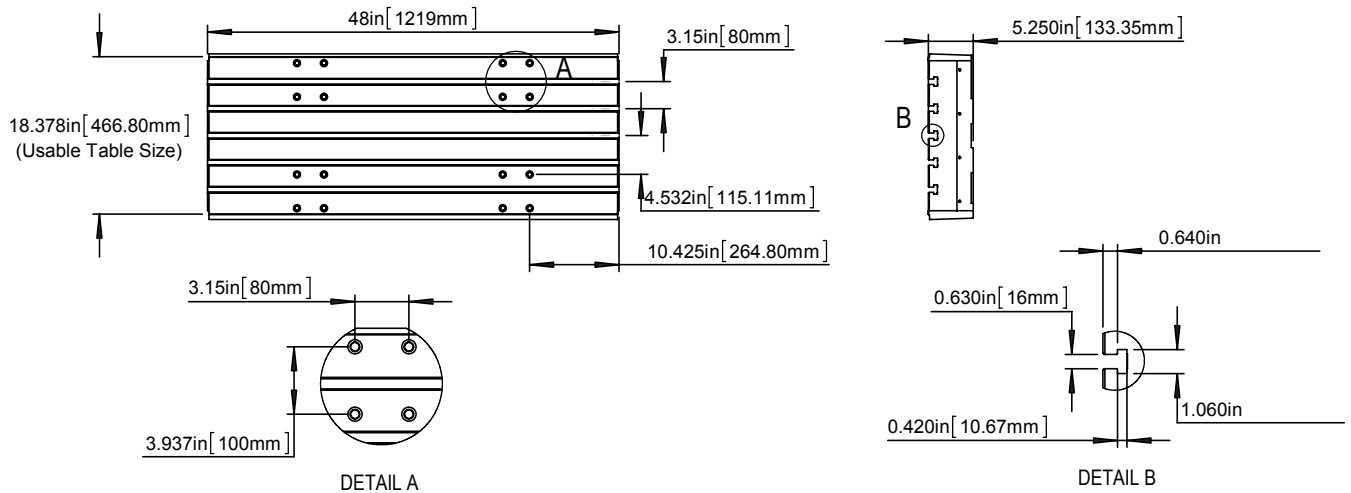

**Inch Low-Profile Table Dimensions**

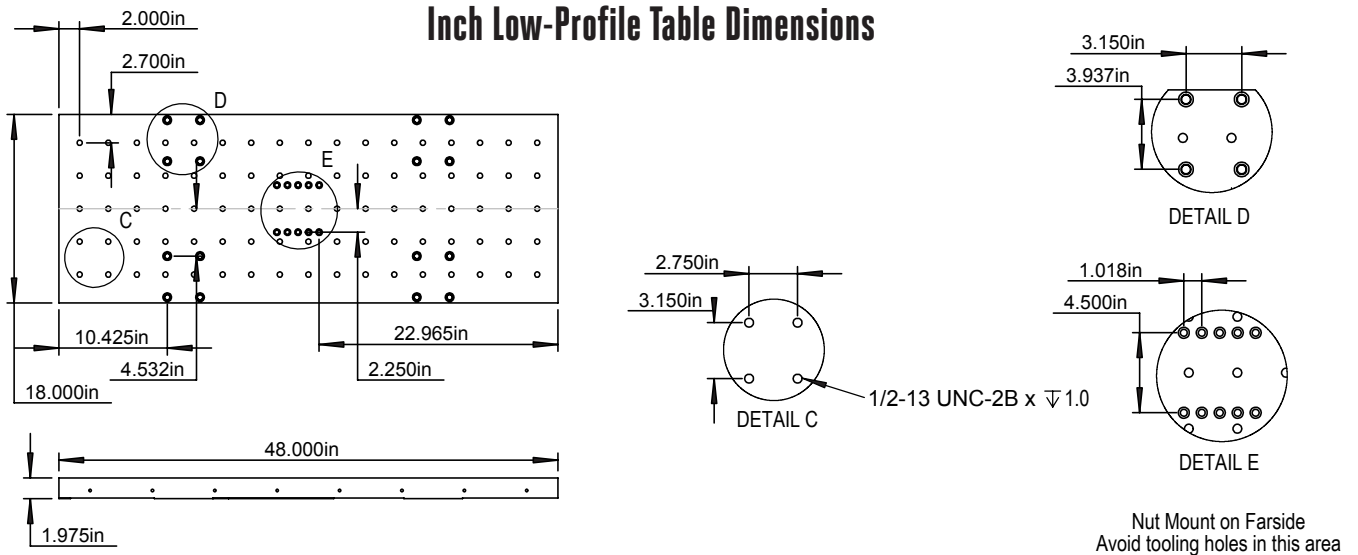

**Metric Low-Profile Table Dimensions**

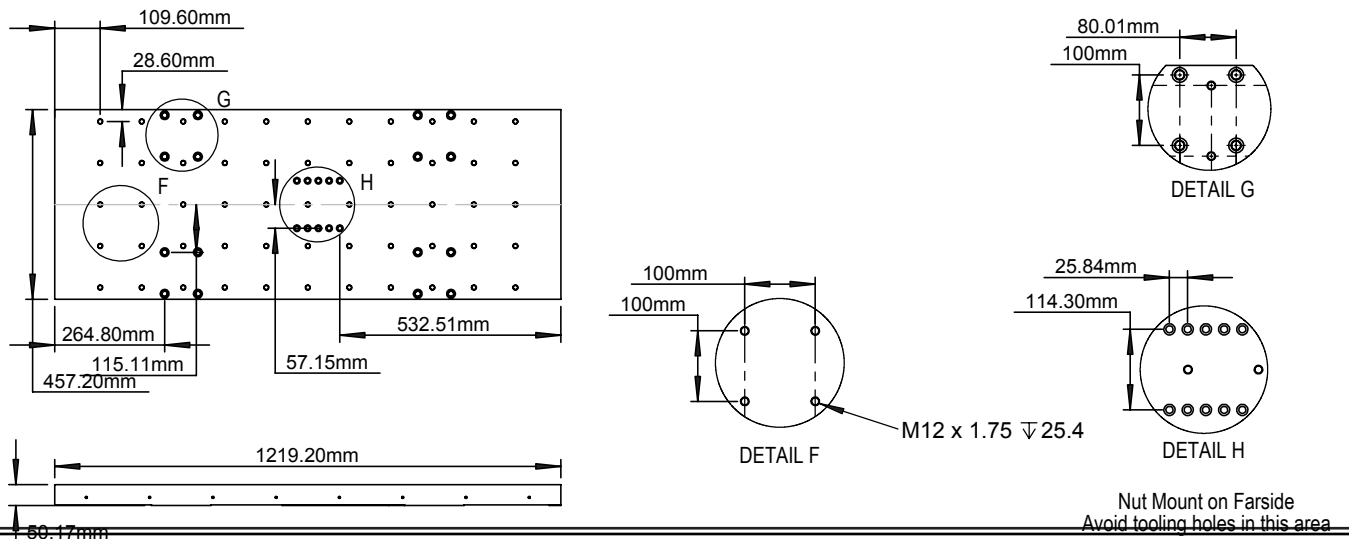

## Umbrella Tool Changer Travels

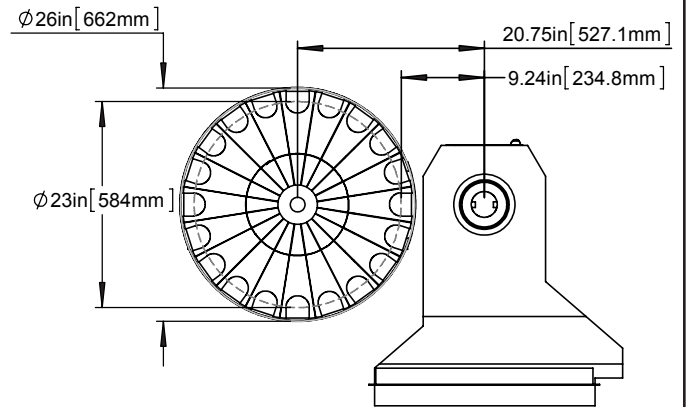
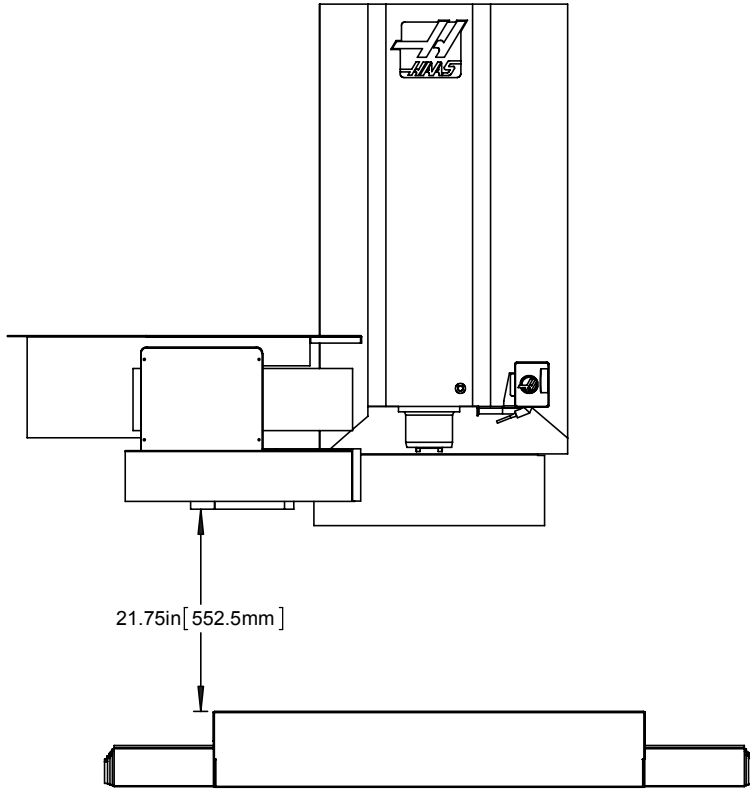

The Umbrella Tool Changer moves in towards the spindle to do a tool change.

Note:  
The Umbrella Tool Changer moves in towards the spindle to do a tool change.